

## Installation Manual

7298000G

# Engineered Pump Systems (EPS)

*for Ordinary and Hazardous Locations*

## Common Components:

- Fiberglass Basin
- Sump, Effluent, Sewage or Grinder Pump(s)
- Inlet Hub
- Control Panel
- Alarm System
- NEMA 4X Junction Box
- Pre-Mounted Float System
- Factory Installed Guide Rail System

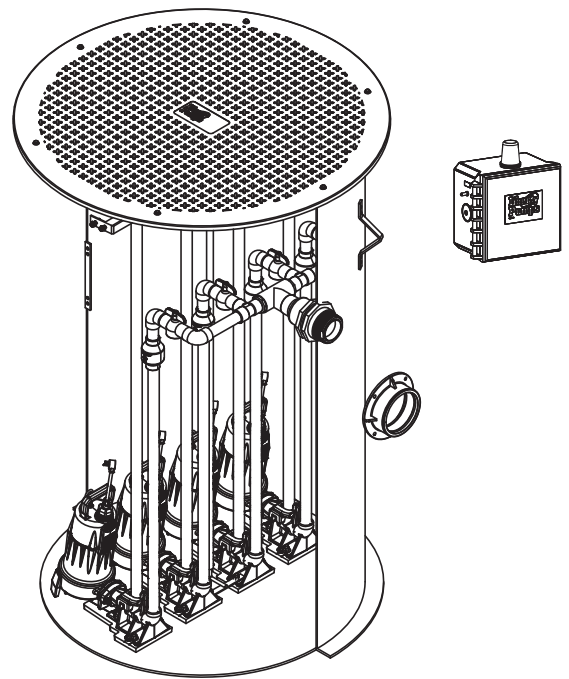

For pressure sewer applications, verify a Redundant Check Valve Assembly (curb stop and check valve) is installed between the pump discharge and the street main, as close to the public right-of-way as possible, on all installations to protect from system pressures.

**IMPORTANT:** All Liberty Pumps systems are supplied with their own separate Installation/Operation/Maintenance manuals. Ensure receipt of these manuals, and that they are read and understood prior to installation. For questions, call Liberty Pumps customer service at 1-800-543-2550.

### **NOTICE**

Installer: Manual must remain with owner or system operator/maintainer.

Record information:

System: \_\_\_\_\_

Model(s): \_\_\_\_\_

Serial(s): \_\_\_\_\_

Control Panel: \_\_\_\_\_

Mfg Date: \_\_\_\_\_

Install Date: \_\_\_\_\_

7000 Apple Tree Avenue  
Bergen, NY 14416  
ph: 1-800-543-2550  
fax: 1-585-494-1839  
www.LibertyPumps.com

Keep this manual handy for future reference.









For replacement manual, visit LibertyPumps.com,  
or contact Liberty Pumps at 1-800-543-2550.

Retain dated sales receipt for warranty.

## Contents

Safety Precautions . . . . .	2   EN
Introduction . . . . .	4   EN
Model Specifications . . . . .	4   EN
Basin Installation . . . . .	4   EN
Preparation . . . . .	7   EN
Installation . . . . .	8   EN
Operation . . . . .	10   EN
Maintenance and Troubleshooting . . . . .	10   EN
Warranty . . . . .	12   EN

## Safety Guidelines

	This safety alert symbol is used in the manual and on the pump to alert of potential risk for serious injury or death.
	This safety alert symbol identifies <b>risk of electric shock</b> . It is accompanied with an instruction intended to minimize potential risk of electric shock.
	This safety alert symbol identifies <b>risk of fire</b> . It is accompanied with an instruction intended to minimize potential risk of fire.
	This safety alert symbol identifies <b>risk of serious injury or death</b> . It is accompanied with an instruction intended to minimize potential risk of injury or death.
 <b>DANGER</b>	Warns of hazards which if not avoided <b>will</b> result in serious injury or death.
 <b>WARNING</b>	Warns of hazards which if not avoided <b>could</b> result in serious injury or death.
 <b>CAUTION</b>	Warns of hazards which if not avoided <b>could</b> result in minor or moderate injury.
 <b>NOTICE</b>	Signals an important instruction related to the pump. Failure to follow these instructions could result in pump failure or property damage.

 **WARNING** Read every supplied manual before using the pump system. Follow all the safety instructions in manual(s) and on the pump. Failure to do so could result in serious injury or death.

**IMPORTANT:** EPS are a custom product and some differences in materials, pumps, and design are unavoidable. This manual is intended as a generic installation guideline only. Any specific questions should be directed to Technical Customer Service at 1-800-543-2550.

## Safety Precautions

### **WARNING** **RISK OF ELECTRIC SHOCK**

- Accidental contact with electrically live parts, items, fluid, or water can cause serious injury or death.
- Always disconnect pump(s) from power source(s) before handling or making any adjustments to either the pump(s), the pump system, or the control panel.
- All installation and maintenance of pumps, controls, protection devices, and general wiring shall be done by qualified personnel.
- All electrical and safety practices shall be in accordance with the National Electrical Code<sup>®</sup>, the Occupational Safety and Health Administration, or applicable local codes and ordinances.
- Do not remove cord and strain relief, and do not connect conduit to pump.
- Pump shall be properly grounded using its supplied grounding conductor. Do not bypass grounding wires or remove ground prong from attachment plugs. Failure to properly ground the pump system can cause all metal portions of the pump and its surroundings to become energized.
- Do not handle or unplug the pump with wet hands, when standing on damp surface, or in water unless wearing Personal Protective Equipment.
- Always wear dielectric rubber boots and other applicable Personal Protective Equipment (PPE) when water is on the floor and an energized pump system must be serviced, as submerged electrical connections can energize the water. Do not enter the water if the water level is higher than the PPE protection or if the PPE is not watertight.
- Do not lift or carry a pump or a float assembly by its power cord. This will damage the power cord, and could expose the electrically live wires inside the power cord.
- The electrical power supply shall be located within the length limitations of the pump power cord, and for below grade installations it shall be at least 4 ft (1.22 m) above floor level.
- Do not use this product in applications where human contact with the pumped fluid is common (such as swimming pools, fountains, marine areas, etc.).
- Protect the power and control cords from the environment. Unprotected power and control (switch) cords can allow water to wick through ends into pump or switch housings, causing surroundings to become energized.
- Single-phase 208/230V pumps shall only be operated without the float switch by using the circuit breaker or panel disconnect.

### / **Applicable to Non-Hazardous Locations** /

- Some ordinary location pumps may have internal capacitors that could cause shock. Avoid contact with plug ends after removing from energy source.

**⚠️ WARNING****⚡ RISK OF FIRE**

- Do not use an extension cord to power the product. Extension cords can overload both the product and extension cord supply wires. Overloaded wires will get very hot and can catch on fire.
- This product requires a separate, properly fused and grounded branch circuit, sized for the voltage and amperage requirements of the pump, as noted on the nameplate. Overloaded branch circuit wires will get very hot and can catch on fire. When used, electrical outlets shall be simplex of the appropriate rating.
- Do not use this product with or near flammable or explosive fluids such as gasoline, fuel oil, kerosene, etc. If rotating elements inside pump strike any foreign object, sparks may occur. Sparks could ignite flammable liquids.
- Sewage and effluent systems produce and may contain flammable and explosive gases. Prevent introduction of foreign objects into basin as sparks could ignite these gases. Exercise caution using tools and do not use electronic devices or have live, exposed electrical circuits in or around basins, open covers and vents.

**/ Applicable to Non-Hazardous Locations /**

- Ordinary location pumps are not to be installed in locations classified as hazardous in accordance with the National Electric Code®, ANSI/NFPA 70.

**⚠️ WARNING****⚡ RISK OF SERIOUS INJURY OR DEATH**

- Energizing the control panel or breaker for the first time is potentially dangerous. Licensed electrical personnel should be present when the panel or breaker is energized for the first time. If faults caused by damage or poor installation practices have not been detected, serious damage, injury or death can result when power is applied.
- Do not modify the pump/pump system in any way. Modifications may affect seals, change the electrical loading of the pump, or damage the pump and its components.
- All pump/pump system installations shall be in compliance with all applicable Federal, State, and Local codes and ordinances.
- Do not allow children to play with the pump system.
- Do not allow any person who is unqualified to have contact with this pump system. Any person who is unaware of the dangers of this pump system, or has not read this manual, can easily be injured by the pump system.
- In 208/230V installations, one side of the line going to the pump is always "hot", whether the float switch is on or off. To avoid hazards, install a double pole disconnect near the pump installation.
- Vent basin in accordance with local code. Proper venting of sewer and effluent gases alleviates poisonous gas buildup and reduces the risk of explosion and fire from these flammable gases.
- Keep clear of suction and discharge openings. To prevent injury, never insert fingers into pump while it is connected to a power source.

- Wear adequate Personal Protective Equipment when working on pumps or piping that have been exposed to wastewater. Sump and sewage pumps often handle materials that can transmit illness or disease upon contact with skin and other tissues.
- Do not enter a pump basin after it has been used. Sewage and effluent can emit several gases that are poisonous.
- Do not remove any tags or labels from the pump or its cord.
- This product contains chemicals known to the State of California to cause cancer and birth defects or other reproductive harm. [www.p65warnings.ca.gov](http://www.p65warnings.ca.gov).
- A grinder pump contains metal parts that rotate at high speeds. Be careful around pump base while power is connected. Make sure that the pump is either in the tank or clear from people and wires when in operation.

**/ Applicable to Non-Hazardous Locations /**

- Do not use this ordinary location product with flammable, explosive, or corrosive fluids. Do not use in a flammable and/or explosive atmosphere as serious injury or death could result.

**/// Applicable to Hazardous Locations ///**

- All electrical and motor repairs and service must be performed by a repair facility approved by Liberty Pumps and certified to work on explosion-proof motor enclosures.
- Refer to Chapter 5 of the National Electric Code® or applicable local codes and ordinances for all electrical and wiring requirements in hazardous locations.
- Float switches must be connected to an intrinsically safe circuit in the control panel as per the requirements of Chapter 5 of the National Electric Code®.
- Hazardous locations contain explosive gases that can be detonated by sparking or electric shock.
- All terminations and penetrations of conduit or cable shall be done using approved materials and methods intended for use to mitigate the potential for explosion.
- All personnel shall be trained and qualified for safe work practices and procedures.
- All installations shall be in compliance with all applicable Federal, State, and Local codes and ordinances for hazardous locations.
- When working in a hazardous location, all precautions to minimize ignition sources such as spark and flame should be taken to limit the potential for fire or explosion.
- All electrical terminations shall be made according to Federal, State, and Local codes for hazardous or classified locations.
- Conduit, junction boxes, and associated components shall be approved for use with hazardous locations and installed according to specifications.
- Use only non-sparking tools and components in and around basins, open covers and vents. Do not use electronic devices that are not rated for use in hazardous locations or have live, exposed electrical circuits in or around basins, open covers and vents. Sewage and effluent systems produce and may contain flammable and explosive gases and sparks could ignite these gases.

## NOTICE

- ◆ Do not exert heavy pressure or run heavy equipment on the backfill material as this could cause the tank to collapse.
- ◆ For pressure sewer applications, verify a Redundant Check Valve Assembly (curb stop and check valve) is installed between the pump discharge and the street main, as close to the public right-of-way as possible, on all installations to protect from system pressures.
- ◆ Do not dispose of materials such as paint thinner or other chemicals down drains. Doing so could chemically attack and damage pump system components and cause product malfunction or failure.
- ◆ Do not use pump system with mud, sand, cement, hydrocarbons, grease, or chemicals. Pump and system components can be damaged from these items causing product malfunction or failure. Additionally, flooding can occur if these items jam the impeller or piping.
- ◆ Submersible Pump—do not run dry.
- ◆ Do not introduce any consumer item that is not toilet paper into a non-grinder (dewatering/effluent or sewage) pump/pump system. This includes, but is not limited to the following: feminine products, wipes, towels, towelettes, dental floss, swabs, pads, etc. Items such as these put the pump under undo strain and can result in pump/pump system failure. Additionally, it creates conditions for discharge line blockage.
- ◆ The Uniform Plumbing Code® states that sewage systems shall have an audio and visual alarm that signals a malfunction of the system, to reduce the potential for property damage.
- ◆ Do not allow pump to freeze.

## Introduction

Pumps and control panels are supplied with their own separate Installation/Operation manuals. Ensure receipt of these manuals, and that they are read and understood prior to installing and using this system. Familiarity with the pump and control panel is critical.

This manual provides a brief overview of the system and deals mainly with inspection and installation of the basin. It does not cover the specifics of the pump or control panel operation. For questions, call Liberty Pumps customer service at 1-800-543-2550.

## Identification

Information about the EPS can be found on a metal tag located on the basin cover. This identifies the EPS model number and electrical specifications per pump, as well as system information and date. Pump tags are located on the pump(s). Duplicate pump tags are packaged with the system. These should be mounted on the basin cover or at the control panel for accessibility and immediate pump information.

## Inspection

Inspect the system upon arrival to ensure that there is no shipping damage. Pay careful attention to the condition of the fiberglass basin, control floats, pump guide rail brackets, and control panel. Notify the carrier immediately if there is any damage.

## Model Specifications

For a complete listing of models and their specifications, refer to [www.LibertyPumps.com/About/Engineering-Specs](http://www.LibertyPumps.com/About/Engineering-Specs). The pump nameplate provides a record of specific pump information.

## Basin Installation

This is a brief reference to the recommended methods and procedures for installing Liberty Pumps underground basins to ensure that damage or premature failure of the basin does not occur.

This section is *not* intended to serve as a basic instructional guide. The installation of Liberty Pumps sump and sewage basins is a specialized skill, and is assumed that the individuals who install our products and refer to this section will have basic understanding of such procedures as excavating, backfilling, pipefitting, and electrical work. No amount of written instruction by a manufacturer or regulatory agency will convert an inexperienced, under-supervised laborer into a skilled, experienced mechanic. The ability to recognize and correctly respond to abnormal conditions during a basin installation requires field experience as well as mechanical aptitude. Figure 1 is provided for reference.

In addition to proper system engineering and competent manufacturing, the use of basin installers who have both practical experience and integrity to assist that the basin be installed properly, constitutes the greatest protection from catastrophic basin failure and liability exposure.

## Basin Handling

### General Handling

Although the exterior surfaces of the fiberglass basins are designed to withstand normal handling, they can be damaged during transportation and installation. Basins must not be dropped, dragged, or handled with sharp objects, and with the exception of the minimal movement involved in a visual inspection, must not be rolled.

### Unloading, Lifting, and Lowering

#### **WARNING** **RISK OF SERIOUS INJURY OR DEATH**

- Under no circumstances are the use of chains or cables around the basin shell permitted.

The proper way to move a basin is by lifting it, using chains or cables with the optional lifting lugs (not more than a 30° angle), or by using a non-marring sling around the basin. Before any attempt is made to move a basin, verify that all equipment and accessories have sufficient capacity and reach to lift and lower the basin without dragging and/or dropping. Maneuver the basin with guide ropes attached to the sides.

### Pre-Installation Inspection

Confirm adherence to the project's specifications before installation. Physically and visually inspect basin, pumps, valves, equipment, and piping materials before installation. Notify the carrier immediately if there is any damage. If the basin or any of its internal components are damaged, suspend installation until a determination of the extent of damage can be made by Liberty Pumps or its agent. Any repairs must be first authorized in writing by Liberty Pumps and then be done in accordance with Liberty Pumps instructions.

### Storage

Store the basin in a secure, controlled area where the potential for accidental damage or vandalism will be minimized. The storage area must be free from sharp objects, rocks, and any other foreign solutions or materials that could cause damage to the basin. Check the basin until it is needed for installation and, if windy conditions are possible, secure the basin with non-marring restraints of a size and number adequate for securing the basin.

### Excavation

#### **⚠️ WARNING** RISK OF SERIOUS INJURY OR DEATH

- Locate all overhead and underground utilities before excavating.

### Excavation Considerations

The excavation must provide adequate space for the basin, piping, and other buried equipment, and for the replacement and compaction of backfill materials particularly around the basin walls. The size, shape, and wall slope of the excavation should be determined by soil conditions, depth of excavation, shoring requirements, and if workers are required to enter the excavation, safety considerations and federal, state, county, and municipal regulations.

### Excavation Location

Excavation for an underground basin must be made with due care to avoid undermining foundations of existing structures and contact with underground utilities. In the absence of building codes or regulations, maintain a minimum distance of 5 feet plus a slope of 45° from the bottom of the compacted sub-base to the bottom of the adjacent structures, foundations, footings, and property lines. Additional distances may be required to ensure that any loading carried or created by the foundations and supports cannot be transferred to the basin.

### Maximum Basin Burial Depth

If burial depth is greater than the basin height, contact Liberty Pumps to determine if additional wall reinforcement is required and secure written authorization.

### Excavated Materials Handling

Carefully store excavated materials, which cannot be removed from the job site, as far from the edge of the basin excavation as possible. Unless approved for use as backfill, securely store excavation materials separate from the approved backfill materials.

### Work Area Safety

Safe installation procedures are the sole responsibility of the basin installer. Work safety requirements are defined in US Department of Labor 29 CFR 1926, Subpart P: Excavations.

### Backfill

Careful selection, placement, and compaction of approved backfill material is critical to a successful basin installation. Among the common problems associated with basin leaks and premature failures are:

- Use of incorrect backfill material
- Inadequate or improper placement or compaction
- Rocks, clods, or debris left in the excavation or basin
- Voids under or around the perimeter of the basin
- Failure to prevent the migration of backfill materials

### Basin Placement

#### **⚠️ WARNING** RISK OF SERIOUS INJURY OR DEATH

- Placement of a basin on a concrete pad or compacted sub-base smaller than the total basin bottom area or on intermediate supports (saddles) will cause uneven distribution of loads. This may contribute to structural failure, and is never permitted.

Cover the bottom of the basin excavation with suitably graded, leveled, and compacted backfill material to a depth of at least 12" (compacted sub-base). If a concrete hold-down/anti-flotation pad is required, this bedding can be reduced to a depth of at least 6". Carefully lower the basin into the excavated area and center on the compacted backfill or concrete pad.

### Backfill Material

Ensure backfill material is clean, well granulated, free-flowing, non-corrosive, and inert; free of ice, snow, debris, rock, or organic material, all of which could damage the basin and interfere with the compaction of the backfill material. The largest particles shall not be larger than 3/4". Not more than 3% (by weight) should pass through a #8 sieve, and the backfill material must conform to ASTM C-33, Paragraph 9.1 requirements. Approved backfill materials include:

- Pea gravel, naturally rounded particles, with a minimum diameter of 1/8" and a maximum diameter of 3/4"
- Crushed rock, washed and free-flowing angular particles between 1/8" and 1/2" in size

### Backfill Placement and Compaction

#### **NOTICE**

- ◆ Do not exert heavy pressure or run heavy equipment on the backfill material as this could cause the tank to collapse.

Compaction of backfill materials must be adequate to ensure the support of the basin and to prevent movement or settlement. Place backfill materials in 12" lifts and compacted to a minimum soil modulus of 700 pounds per square foot.

**⚠ WARNING**  **RISK OF SERIOUS INJURY OR DEATH**

- Using the basin to support any loading carried or created by piping, equipment, cribbing, bracing, or blocking is never permitted.

Provide support for piping, equipment, and other accessories during backfilling. During backfilling, temporary support must be carefully installed and removed to prevent damage to the basin, piping, and/or equipment.

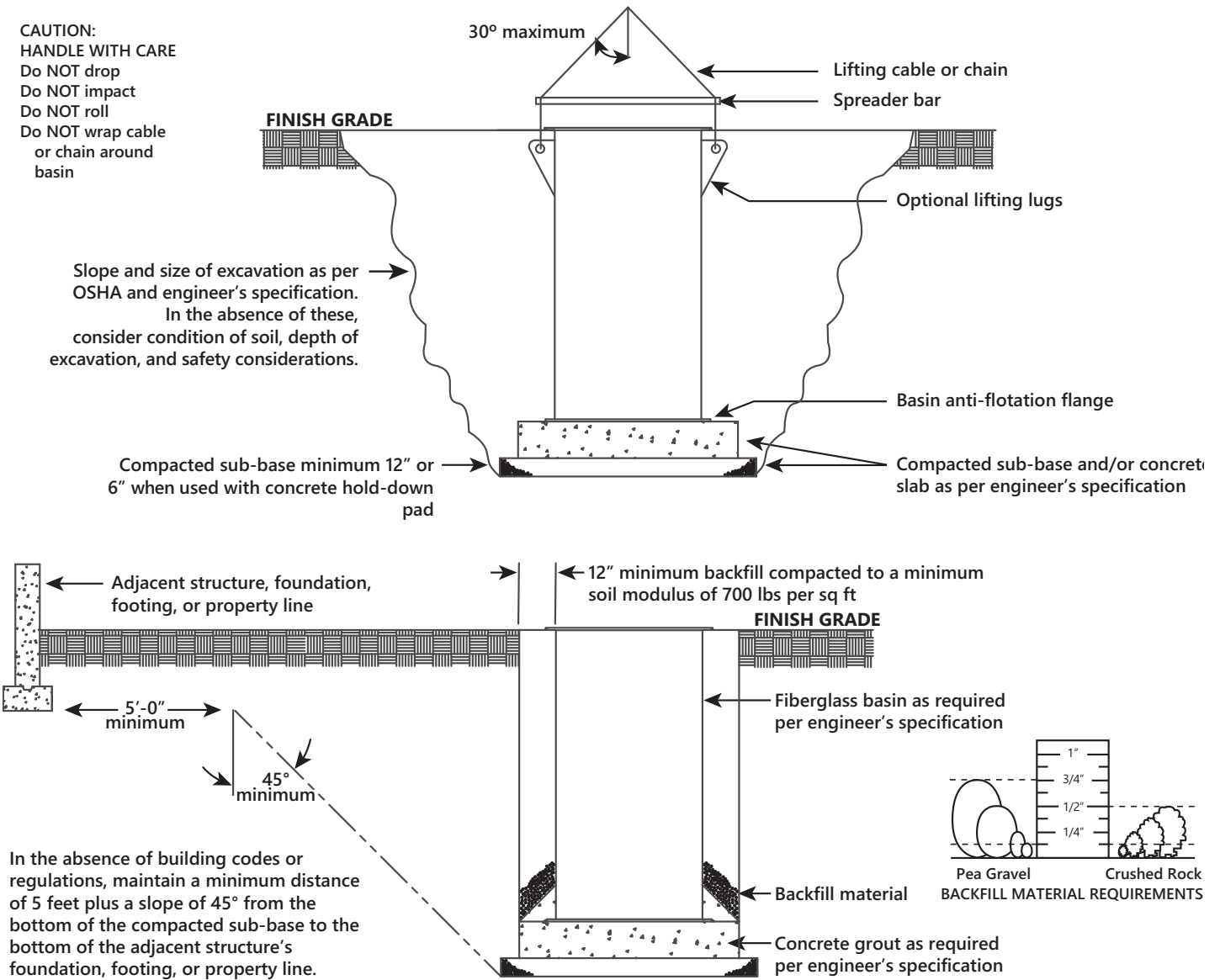

**NOTE:** The intent of these installation instructions and illustration is to ensure that damage or premature failure to the basin does not occur. These installation instructions and illustration are not intended to preclude normal safety procedures that should be followed to prevent injury to personnel.

**SAFE INSTALLATION PROCEDURES ARE ENTIRELY THE RESPONSIBILITY OF THE INSTALLER**

Figure 1. Basin Installation Reference

## Anchorage

When basin installations are located in areas subject to high water tables or flooding, make provisions to prevent the basin, either empty or filled, from floating. The buoyancy force to be offset is determined primarily by the volume of the basin. The principle offsetting factors include:

- Backfill materials
- Concrete hold-down pad
- Friction between the basin, backfill materials, and surrounding soil

### Anchorage Methods

All methods of anchoring the basin use the weight of the backfill materials to offset the buoyancy forces. The use of supplemental mechanical anchoring methods (i.e., a concrete hold-down pad) increases the amount of backfill ballast, which is mechanically attached to the basin. The recommended method of attachment is to pour concrete grout over the basin's anti-flotation flange and concrete hold-down pad.

### Anchorage Requirements

#### **⚠ WARNING** RISK OF SERIOUS INJURY OR DEATH

- Use "submerged" material weights when calculating anchorage requirements.

Requirements of anchorage, thickness of concrete hold-down pads, as well as the size of anchors and reinforcement must be calculated for each installation based on the environmental conditions of the specific installation.

**Example:** weight of concrete (150 pounds per cubic foot) minus the weight of the water (62.4 pounds per cubic foot) equals a "submerged" weight of 87.6 pounds per cubic foot.

## Preparation

### Install Pump Control and Alarm Floats

EPS are commonly supplied with a control panel that will either use float switches or a pressure transducer to detect the water level in the basin. If present, the float switches are pre-mounted on a QuickTree®. For QuickTree removal, loosen the cord nut and pull the QuickTree straight out of the basin.

### Field Mounting Float Guidelines

Most EPS leave the factory with float heights already set. If this is not the case or floats require adjustments, follow these guidelines to set floats in the field.

EPS typically include a 3 float control panel in a simplex or 4 float control panel in a duplex configuration. Correct height settings for each float are critical for optimal pump cycling and operation of the system.

Since basin heights vary with each system, use the centerline of the inlet hub as the baseline for measuring the distance of the top two floats (ALARM and ON). The lowest float (OFF) is measured from the basin bottom. All distances are measured to the center of the float cord at the attachment point on the float tree.

### Float Level Adjustment Constraints

- Do not raise the alarm float higher than 9" below the inlet centerline or fluid will start backing up the inlet line prior to ALARM activation.
- Do not lower the OFF float below the 13" minimum. Pump shutoff needs to occur while the impeller is still submerged in fluid to prevent air entering the impeller cavity.
- Maintain at least a 6" minimum differential between the bottom of the ALARM float and the bottom of the ON float.
- The ON float can be lowered or the OFF float raised to reduce the volume per pump cycle.
- It is not recommended to make adjustments of more than 3" in either direction. Contact Liberty Pumps if adjustment is needed to the pump cycle beyond these recommended levels.
- Float settings are factory set for maximum per cycle volume.

### 3-Float Settings for Maximum Per-cycle Volume

Make note of the inlet height.

1. ALARM float (highest) 9" from centerline of inlet to float cord.
2. ON float (middle) 15" from centerline of inlet to float cord.
3. OFF float (lowest) 13" from bottom of basin to float cord.

### Example Float Settings:

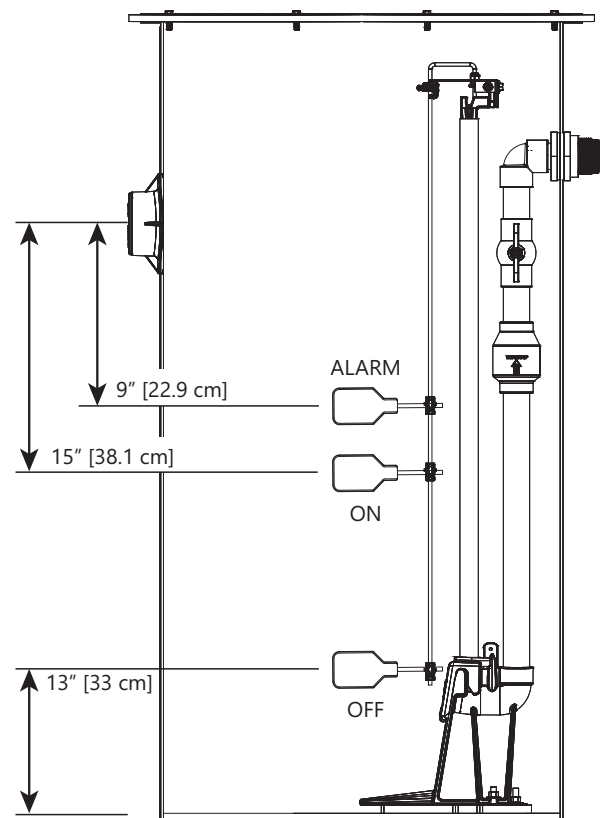

## Installation

### **⚠️ WARNING** ⚡ RISK OF ELECTRIC SHOCK

- All installation and maintenance of pumps, controls, protection devices, and general wiring shall be done by qualified personnel.
- All electrical and safety practices shall be in accordance with the National Electrical Code®, the Occupational Safety and Health Administration, or applicable local codes and ordinances.

### **NOTICE**

- ◆ For pressure sewer applications, verify a Redundant Check Valve Assembly (curb stop and check valve) is installed between the pump discharge and the street main, as close to the public right-of-way as possible, on all installations to protect from system pressures.

## Electrical Connections

With mains power disconnected, complete pump, control panel and alarm connections per wiring diagrams included with their own Installation manuals, as applicable. Verify connections. When complete, check all wires for unintentional ground.

## 3-Phase Pump Rotation Verification

### **NOTICE**

- ◆ Check 3-phase pumps for proper rotation prior to installing pump(s) in basin. To change rotation, reverse any two of the three power leads to the pump (not the ground). Code the wires for reconnection after installation.

To ensure that the power to the pump is installed correctly, always verify proper rotation **before** lowering it into the basin. If the pump is rotating in the wrong direction, turn power OFF and reverse any two leads. This reverses the phase sequence and corrects the pump rotation. For 3-phase pumps, rotation must be counter-clockwise when looking from the bottom (clockwise when looking from top) of the pump.

## Discharge

Connect appropriate pipe rated for at least 200 PSI to the pump discharge. Do not increase the discharge piping to a larger size than the pump can handle. Do not reduce the discharge to below the pump outlet size. The remainder of the discharge line should be as short as possible with a minimum number of turns to minimize friction head loss.

## Pressure Sewer Applications

A redundant check valve assembly consisting of a curb stop and check valve must be installed between the pump discharge and the street main, as close to the public right-of-way as possible, on all pressure (force main) sewer installations to protect from system pressures. The curb stop valve is necessary to isolate the site from the pressure sewer while the check valve provides redundant protection against potentially detrimental backflow. All valves and fittings should be rated for at least 200 PSI service.

See Liberty Pumps line of CSV-Series Curb Stop/Swing Check Valve Assemblies and CK-Series Connection Kit.

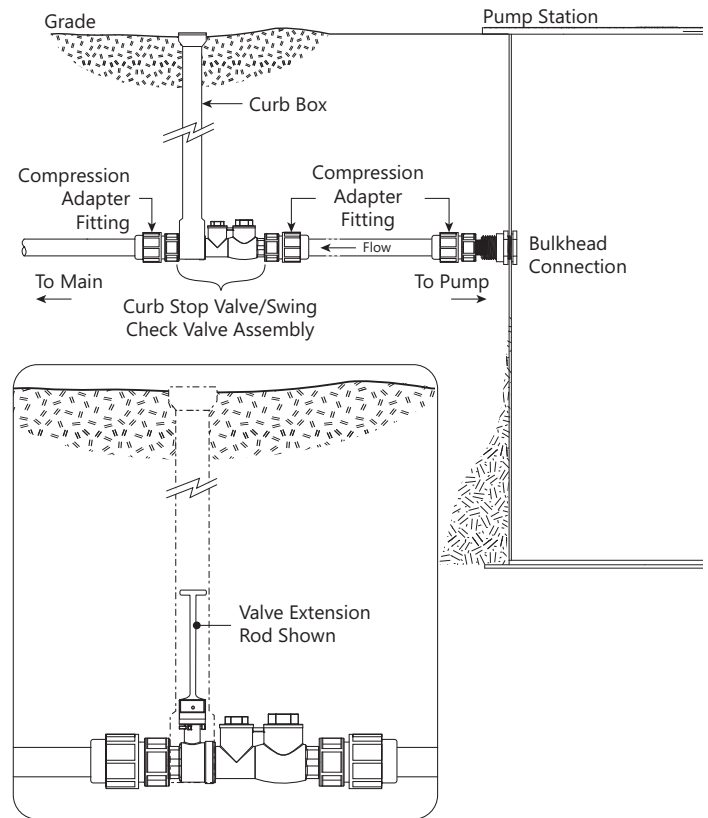

## Vent

The fiberglass basin provided with the system must be completely sealed and properly vented per local health and plumbing code requirements. If the system is to be vented through the inlet to an existing building vent stack, there must be no traps between the system inlet and the nearest building vent stack connection (option 1). If this is not possible or desirable per the application, a standalone vent can be installed in tank side (option 2) or a vent flange or grommet can be installed in a hole cut into the cover (option 3).

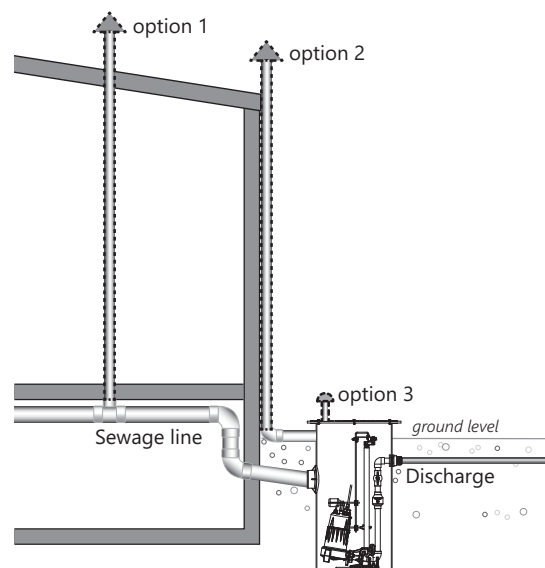



**Inlet**

Connect the inlet line to the inlet hub per engineer's specifications.

**GR-Series Guide Rail System**

The optional GR20, GR22, GR30, GR3 or GR4 quick-disconnect assembly guide rail system provided with the EPS system is designed to allow easy installation and removal of the pump. When installed correctly, it will seal and provide a means to lift the pump without disconnecting any of the discharge piping. Ensure installation is done as shown.

Hazardous location guide rail systems are available from Liberty Pumps. These "NS" models (GR20NS, GR22NS, GR30NS, GR3NS, GR4NS) have identical performance to the GR-Series models shown, except they have a bronze (non-sparking) claw.

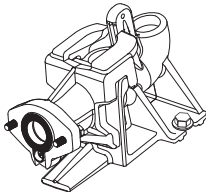
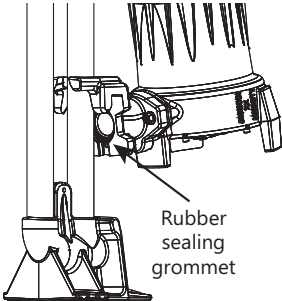
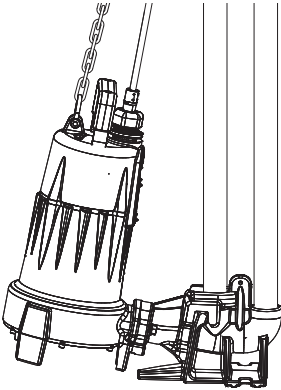
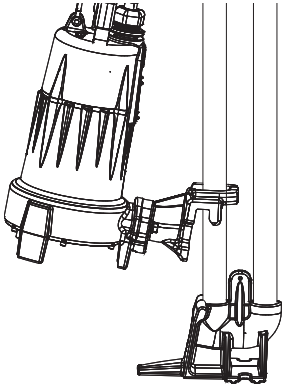
<b>GR20-SERIES</b>		
	<b>Guide Rail Base</b>	<b>Grommet Location</b>
<b>GR20-SERIES</b>		
	<b>Operating Position</b>	<b>Disconnected Position</b>

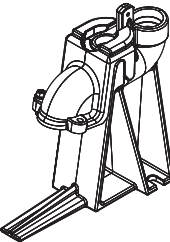
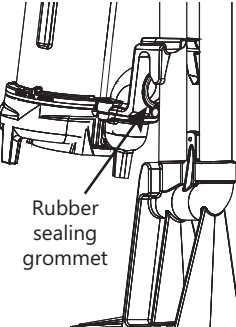
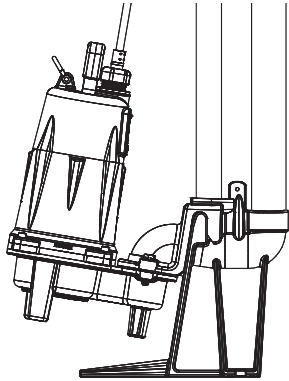
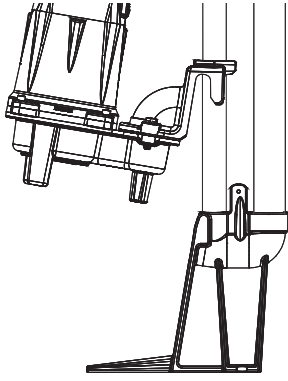
<b>GR22-SERIES</b>		
	<b>Guide Rail Base</b>	<b>Grommet Location</b>
<b>GR22-SERIES</b>		
	<b>Operating Position</b>	<b>Disconnected Position</b>

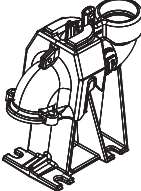
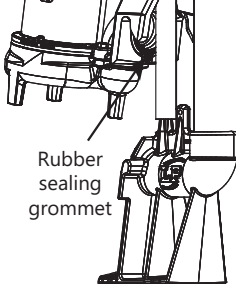
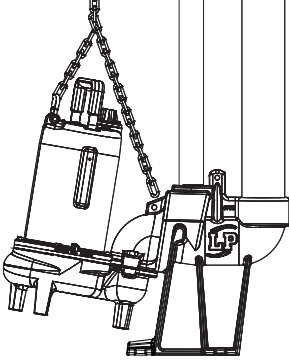
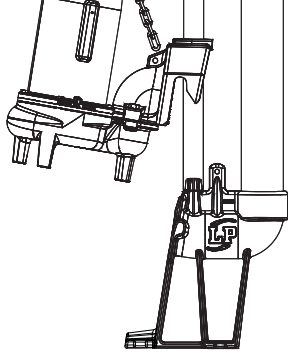
<b>GR30-SERIES</b>		
	<b>Guide Rail Base</b>	<b>Grommet Location</b>
<b>GR30-SERIES</b>		
	<b>Operating Position</b>	<b>Disconnected Position</b>

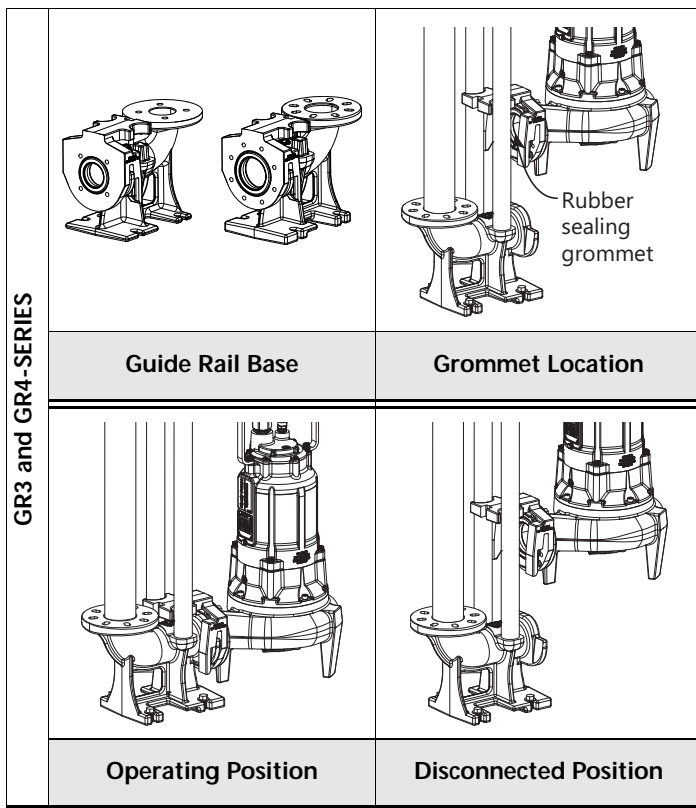

### Check pump for jam

Each sewage pump has a solids handling specification that it is designed to pass. A grinder pump will grind any solids into a slurry, and then pump them out. Occasionally a pump used to pump sewage will become jammed on a large solid, especially when it is not the intended usage. When a pump is jammed, foreign material is keeping the impeller or cutter (grinder pumps only) from rotating, which effectively stops the motor. If a pump remains ON in this condition, the pump will hum and will usually overheat itself and turn OFF due to thermal overload.

**To check for a jam**, remove pump from basin. Always disconnect the pump from electrical power before checking for a jam. Since the pump inlet is located on the bottom of the pump, put the pump on its side or fixture it upside down to look at the inlet. Inspect the impeller or cutter for any foreign material, and try to spin the motor shaft. If it is unable to rotate, the pump is jammed. Locate the jam, and remove whatever is restricting the impeller or cutter. A grinder pump has such a small gap that it may require the cutter to be hit with a screwdriver and hammer in the reverse direction to remove any foreign material.

### Pump not seated properly on guide rail base

Guide Rail Systems feature a self-aligning mounting bracket. When properly installed, the pump will sit at an angle with the guide rail claw seated firmly on the guide rail base. The guide rail grommet will be compressed by the weight of the pump. If the pump does not seat properly, the grommet will not seal, which will result in blow-by when the pump turns ON. The same could happen if the guide rail grommet is out of place. This could result in the water not evacuating the tank, longer cycle times, pump overheating, and possibly even damage to the system.

**To fix this problem**, use the lifting chain or other lifting means to move the pump into correct position with respect to the guide rail (see *GR-Series Guide Rail System*).

### Check voltage at panel

When pumps need to be installed long distances from a power source, attention must be given to properly size the wire. Considerations must be made for the pump's required voltage, phase, full load amps, and length of wire. Proper sizing should be done by an electrician, although using a sizing tool as a guide provides a close approximation. This would be a better alternative than guessing or even worse, using the same gauge wire as the pump was supplied with. When insufficient wire size is used, there will be a voltage drop across the wire (anything higher than a 3% drop would be insufficiently sized).

**To detect a voltage drop**, measure the voltage at the implementation point (usually the control panel) with the pump running. This shows what voltage the pump is seeing. Measuring the voltage while the pump is running provides a good indication of the voltage drop while the pump is under load. Pump must not be used in voltage extremes greater than it was designed to handle.

## Operation

Refer to the Startup and Operation sections provided in the supplied pump, control panel, alarm manuals as applicable.

## Maintenance and Troubleshooting

Refer to the Maintenance and Troubleshooting sections provided in the supplied manuals.

Because an EPS can contain a large array of components, it would be ineffective to include a complete troubleshooting list for each and every combination of components. The most common causes and corrective actions are addressed in this section. For further questions, contact customer service at 1-800-543-2550 or support@LibertyPumps.com.

### PUMP RUNNING, BUT NOT PUMPING

#### Closed ball valves at street / inside tank

Ball valves may be closed initially while the system is not in service. A closed ball valve will not allow a pump to remove any water and would run continuously. This could cause overheating and damage to the system. A closed ball valve has the handle perpendicular to the valve; an open ball valve has the handle parallel to the valve.

**Check all ball valves are open** and make sure that all pumps in the system are able to evacuate water.

<b>PUMP NOT TURNING ON</b>
<b><i>Check control floats for obstruction</i></b>
<p>If something inside the tank obstructs the float switch from rising, it would not be able to activate and the control panel would not operate the pumps. This would usually result in the high level alarm triggering or flooding. Likewise, if a float switch is trying to drop and it cannot because it is obstructed by another object, it would not signal the control panel to disengage the pumps and they would run continuously. This would result in overheating or damage to the system.</p> <p><b>The floats require free movement</b> throughout their cycles. Check for obstruction from anything inside the tank, including the pumps and power cords.</p>
<b><i>Check control panel power</i></b>
<p>The circuit powering the controls must be separate from the circuit powering the pumps. There will be a dedicated set of terminals to connect power to the control circuitry. Failing to adequately and appropriately power the controls will result in the pumps not operating automatically.</p> <p><b>Most panels have an LED that will turn ON</b> when control power is properly installed.</p>
<b><i>Check for blown control fuse</i></b>
<p>Control panels will usually have circuit breakers or other overload protection to protect a pump from burning itself out from overdrawing current. Similar to this, the control circuit has its own built-in protection in the form of a fuse. Usually there will be two circuits, one for control power and one for alarm power. Each will have its own fuse that would blow under a high amperage condition. If power is not reaching the control circuitry, it is possible that the control power fuse has blown and would need to be changed.</p> <p><b>Check the fuse.</b> For convenience, the control panels are equipped with replacement fuses of the correct size on the inside of the front door.</p>
<b><i>Troubleshoot control panel in HAND mode</i></b>
<p>Control panels should come equipped with HAND-OFF-AUTO (H-O-A) switches that can be used to change the operation of the control panel. The HAND mode is for manual operation. If the control panel is set to HAND mode, it will automatically run the pump no matter what the current liquid level is, while the OFF mode does the opposite. The AUTO mode is the normal operation mode. In AUTO mode, the floats (or in some cases transducer) will trigger the control panel to operate the pump, turning ON when the liquid level reaches a certain height, and turning OFF when the liquid level falls to a certain height.</p> <p><b>If the pump is not turning ON in the AUTO mode,</b> troubleshoot the system by temporarily changing the control panel to HAND mode. If the pump operates and pumps down the liquid level, this would signify that the problem is with water level sensing, most likely one of the floats is not working correctly. It could be out of position, obstructed, or defective.</p>

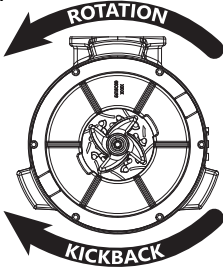
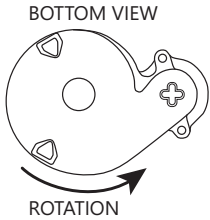
<b><i>Troubleshoot by adding water to the tank</i></b>
<p>Run the pump through a cycle by adding water into the basin in order to operate the pump. If adding water is not an option, raising the float switches by hand in the order that they would normally raise would simulate water entering the pit. If the pump turns ON, evacuates the water, and turns OFF, then the system is working properly.</p> <p><b>By raising the floats by hand or with water,</b> it is easy to tell if a float is not functioning depending on whether or not it turns on its corresponding LED.</p>
<b>ISSUES EXCLUSIVE TO 3-PHASE SYSTEMS</b>
<b><i>Check 3-phase pump rotation</i></b>
<p>Three phase power uses three separate alternating currents that peak at different integrals. With a pump that is powered by three phase electric, the phase sequence of the motor must match the phase sequence of the power source. When the sequences match, the pump will operate properly. However, when the phases are out of order, the pump will run backward (i.e., the impeller will rotate in the wrong direction). This will cause an extreme loss of performance and could raise the amps drawn by the pump.</p> <p><b>To ensure that power to the pump is installed correctly,</b> always check the rotation of the pump before lowering it into the pit. The correct rotation is shown below for a grinder and sewage pump. If the pump is rotating in the wrong direction, turn off the power and reverse any two leads (not ground). This will reverse the phase sequence and will correct the pump rotation.</p>
<div style="display: flex; justify-content: space-around; align-items: flex-start;"> <div style="text-align: center;"> <p><b>Grinder</b></p>  </div> <div style="text-align: center;"> <p><b>Sewage</b></p>  </div> </div>
<b><i>Check overloads for tripping</i></b>
<p>All 3-phase control panels have overload protection set for a certain amp rating based on the pump being used.</p> <p><b>To reset the switch,</b> turn to the ON position. Note that switches come in the OFF position. They must be reset during installation to be able to supply power to the pumps.</p> <p><b>To check that the amp level is correct,</b> verify with the tag located on the pump. There will be an FLA listed on the tag. The setting on the overload should be set at least this high, and could be set as much as 10% or 1 amp higher, whichever is greater. Not having this set correctly could result in nuisance tripping of the overload, which in turn would not allow the pump to operate.</p>

### **Confirm transformer connections**

Three-phase panels power the controls through a transformer that will accept three phase power and convert it to 120 V, 1-phase for control power. All Liberty Pumps 3-phase panels are designed to be able to run on 208 V, 240 V, and 480 V three phase electric, and thus an adjustable transformer is required.

**To accommodate each different voltage**, there is a lead to the primary voltage tap to the transformer that needs to be connected. This lead will come with a label to instruct which terminal to connect to, based on which voltage is being used. If this lead is not connected, the transformer will not deliver power to the controls of the panel and the panel will not be able to operate the pumps. If this lead is incorrectly connected, the control panel circuits could be damaged.

### **PRESSURE SEWER APPLICATIONS**

*Pump runs but does not turn off*

*Pump cycles too frequently*

*Rupture or failure of discharge plumbing either inside or outside of the basin*

*High level alarm triggering*

**Missing or faulty curb stop/swing check valve** allowing system pressure to feed back through discharge piping. Verify presence of a curb stop valve or replace curb stop/swing check valve assembly.

## Warranty

### **Liberty Pumps Wholesale/Commercial Series Products Limited Warranty**

Liberty Pumps, Inc. warrants that Liberty Pumps wholesale products are free from all factory defects in material and workmanship for a period of three (3) years from the date of purchase (excluding batteries\* and **Commercial Series**\*\* models). The date of purchase shall be determined by a dated sales receipt noting the model and serial number of the pump. The dated sales receipt must accompany the returned pump if the date of return is more than three years from the date of manufacture noted on the pump nameplate.

The manufacturer's sole obligation under this Warranty shall be limited to the repair or replacement of any parts found by the manufacturer to be defective, provided the part or assembly is returned freight prepaid to the manufacturer or its authorized service center, and provided that none of the following warranty-voiding characteristics are evident:

The manufacturer shall not be liable under this Warranty if the product has not been properly installed, operated, or maintained per manufacturer instructions; if it has been disassembled, modified, abused, or tampered with; if the electrical cord has been cut, damaged, or spliced; if the pump discharge has been reduced

in size; if the pump has been used in water temperatures above the advertised rating; if the pump has been used in water containing sand, lime, cement, gravel, or other abrasives; if the product has been used to pump chemicals, grease, or hydrocarbons; if a non-submersible motor has been subjected to moisture; or if the label bearing the model and serial number has been removed.

Liberty Pumps, Inc. shall not be liable for any loss, damage or expenses resulting from installation or use of its products, or for consequential damages, including field labor costs, travel expenses, rental equipment, costs of removal, reinstallation or transportation to and from the factory or an authorized Liberty Pumps repair facility.

**There is no other express warranty. All implied warranties, including those of merchantability and fitness for a particular purpose, are limited to three years from the date of purchase. This Warranty contains the exclusive remedy of the purchaser, and, where permitted, liability for consequential or incidental damages under any and all warranties are excluded.**

\*Liberty Pumps, Inc. warrants StormCell® batteries for 1 year from date of purchase.

\*\*Liberty Pumps, Inc. warrants that pumps of its **Commercial Series** are free from all factory defects in material and workmanship for a period of 18 months from the date of installation or 24 months from the date of manufacture, whichever occurs first, and provided that such products are used in compliance with their intended applications as set forth in the **Commercial Series** technical specifications and manuals. The date of installation shall be determined by a completed pump start-up report and warranty registration form. A pump start-up report, filled out by a qualified installer, is required for warranty to take effect. The report must be submitted within 30 days from the installation date and submitted through the Liberty Pumps website.

**[www.libertypumps.com/wp/dom/Services/Warranty/Commerical-Series-Startup-Form](http://www.libertypumps.com/wp/dom/Services/Warranty/Commerical-Series-Startup-Form)**